

# Gonzalo Carro

## ◀ DIGITAL CREATOR ▶

Text by Muriel  
Photos and instructions by Gonzalo Carro  
(@brick\_fan\_uy)





**W**hen the theme of medieval times was proposed for HBM038, the idea was to do an article by one of the AFOLs who share their digital instructions with the community in an altruistic way. Personally, I did not know Gonzalo; Jetro sent me his Instagram profile a long time ago for me to take a look. Later, I was talking to a fellow AFOL colleague known for his medieval taste who also recommended that I take a look at a particular profile. We are talking about the account @brick\_fan\_uy, and behind this account is Gonzalo Carro. We present this interview with him so that those of you who don't know him yet will know and enjoy his content.

**HBM:** Hello Gonzalo, tell us a little about yourself. Where are you from? Your age? What do you do? And do you belong to a LUG?

**GC:** I am a Telecommunications Engineer, I am 35 years old, and I live in Montevideo, Uruguay, where I was born.

**HBM:** Is it easy to get LEGO in Uruguay?

**GC:** If we talk about getting LEGO like buying a set, it is much easier than it was when I was a kid. Back then it was very, very rare that anyone sold LEGO in my country. In that sense I was lucky as a kid because my parents could get some sets on the border with Brazil where we had a summer house. Nowadays you can get them, but in general they are sets one or two years old and mostly oriented to young children. The LEGO store in Uruguay is nothing like the LEGO stores in other countries. There is no wall of pieces, nor is there a LEGO web page to buy at B&P. That is to say, for the services that an AFOL might want to use, access to LEGO in my country is much inferior to what is available in Europe or the United States. The way for me to get parts is to buy them on eBay or BrickLink in the US and pay international freight from there to my city, in addition to having to pay import taxes.

**HBM:** Are there a good number of AFOLs out there?

**GC:** No, I only know of one other besides me, but he has no public activity on social networks.

**HBM:** How long have you been building with LEGO and how did you start?

**GC:** As a kid it was my favorite toy. According to my calculations I must have played with LEGO from 1992 to about 1999. Then when I grew up, I took it up again during the fateful year 2020. One day looking for something else at home I found my saved collection. . . I started to assemble the sets and since then I haven't stopped.

**HBM:** Did you also suffer the "dark ages"?

**GC:** Yes, my dark ages were approximately from 1999 to 2020.

**HBM:** Do you have a favorite piece and color preference in your builds?

**GC:** Yes, my favorite piece is the "masonry brick" 98283 in Light Bluish Gray. It's a piece that I knew growing up and is excellent for texturing any Castle-style building.

**HBM:** What would you say are your favorite official and unofficial lines par excellence? Do any themes inspire you apart from medieval and Viking?

**GC:** My favorite lines are the ones from my childhood: Castle, Pirates, and Space. In that order. Of the new ones, I like Ninjago and Creator 3-in-1. I'm not a fan of the licensed themes. At the moment, the medieval theme inspires me the most, because it was my favorite and because of how vast it is. No two castles are the same and I am a fan of the architecture of that era. Vikings are another theme that has inspired me a lot; I started building Viking MOCs when I started playing the Valheim Game last year. The Norse are a fascinating people. Sometimes they seem like fantasy stories and with very distinctive architecture so I spent quite a bit of time on them.

**HBM:** Where do you get the inspiration for these themes? Do you document or let your imagination run wild?

**GC:** Inspiration comes in a moment, when I see something and I start to imagine it in LEGO. Then comes a stage of googling information about that object, whether it's a castle, a ship, a house, or whatever. Since I build historical things, I always like to be able to include realistic details as much as I can. The limit is set by playability and the amount of pieces required. That is to say if by making the MOC realistic I have to sacrifice playability (access to interiors, etc), or if it takes me a million pieces to make something that only adds a small share of realism, it doesn't happen.

**HBM:** Why did you start posting on Instagram and on Rebrickable? What motivates you to build and share medieval and viking themed tutorials with the community?

**GC:** In 2020 during the pandemic, upon finding my childhood LEGO collection, I did what anyone would have done today – I took pictures of what I built to share with my family or friends. Soon after that, and already being an IG user, I searched for LEGO accounts and came across a whole community. That's why I started the profile as brick\_fan\_uy (the name is self-explanatory). As soon as I uploaded some pictures of my clumsy creations I started connecting with other AFOLs

and one of them told me that Studio software existed. I had tried to use LDD without much success, and Studio for some reason seemed simpler and opened a world of new possibilities. Once the limitation of getting parts was lifted, I started to build everything I could imagine. Then I learned how to make instructions and put them on Rebrickable.

My motivation to share the tutorials is to contribute to the AFOL community on the internet. Talking to different people from different cultures, I realized that there are those who have many pieces but find it difficult to create, those who have ideas but lack pieces, and of course those who have both the pieces and ideas. In general those are the brackets. My idea with the tutorials is to share my creations so that those who do not find it easy to create from scratch can take it as a reference, modify it and make it their own. Luckily that has been the case with many of the MOCs I've published, especially the Modular Castle series. I share them for free because my livelihood is my day job. . . it won't make a big difference to me to sell PDFs day in and day out. . . and I find that the return from other AFOLs either thanking me or showing me their builds is far superior to simply charging money. Likewise, there are generous members of the community who insisted on collaborating, so I opened a web piggy bank to receive voluntary donations. I have also received gift pieces from other members of the community, which has been very gratifying.

I also recently authorized a supplier to sell some of my MOCs with compatible parts. These parts are those which are no longer protected by LEGO licenses so there is nothing illegal about it, and each MOC is checked to make sure it is compliant. It seemed like one more way to get my designs out to more people, to include them, since not everyone is willing to learn "the Bricklink dance" or has the money to buy all the original LEGO pieces. Being legal, I prefer to do everything to include people in the fun of the LEGO community, although I confess it was a difficult decision to make, given the bad reputation that compatible pieces have. We'll see how that goes.

**HBM:** You have more than 10k followers on IG, did you think you would reach so many thousands sharing your creations?

**GC:** Not at first and it wasn't my goal or desire either. I simply wanted to share what I was putting together and comment on the posts that others were making. Then when I noticed that the number of followers was growing I paid a little more attention to the number. Sharing tutorials

was key to the increase in followers, but it's not why I do it frankly.

**HBM:** Do you have any anecdotes regarding your experiences as a LEGO fan?

**GC:** Once when telling a community member that I had never been able to own a Forestmen set, he sent me five vintage Forestmen minifigures in the mail. Also, another member of the community helps me by building the designs I make in Studio to verify the stability and robustness of the constructions, without asking me anything in return and just for the pleasure of doing it. Others have also sent me minifigures, parts, books, and even sets. They are sympathetic to know that the reality of an AFOL in my country is so different from theirs in terms of access to parts. They are all friends on IG that chat on an almost daily basis.

**HBM:** What are your favorite reference sites for building with LEGO?

**GC:** Rebrickable for MOCs, Bricklink for official sets, and Back of the Box Builds for building the designs on the back of vintage LEGO boxes.

**HBM:** Did you know about Hispabrick magazine and the MILS system?

**GC:** I didn't know it, but discovered the MILS system while researching a couple of weeks ago. It was suggested to me when I asked in the

community what to do with some bent baseplates I have. I think it's great, although by the scale of constructions that are made I don't think it's something I can dedicate myself to.

**HBM:** Do you miss any specific site, or do you think that there is anything missing online related to our hobby, in spite of the net being so wide?

**GC:** The site I miss the most is LEGO.com. Having access to all the services LEGO offers would be amazing. If we are talking about a service that doesn't exist today, I don't know. . . I still find it fascinating that Bricklink, Rebrickable, and LEGO Ideas exist. It might be some minifigure exchange service, but maybe that already exists. One service I would like to see would be providing the ability to send your design to a company that would manufacture the parts to build it, but I can think of several reasons why that might not be entirely feasible.

**HBM:** Would you like LEGO to bring out "Castle" lines again?

**GC:** Yes, I would. But at the same time I don't think it would be enough. If they have discontinued it, it must be because it was not being profitable. Nobody can argue with LEGO about that. Who, if not them, knows what the numbers say, and the numbers rule in every company. I think that if the Castle line comes out

again it should not be with the same style/spirit as before, but be oriented to those of us who were kids during the golden age of Castle and today are AFOLs. In any case it is LEGO's decision. Initially in my IG posts I used to include the hashtag #bringBackLEGOCastle, in an attempt to generate traction for them to re-release it. Then I understood that even if they did release it, I'd like to keep doing what I do. LEGO is never going to keep everyone happy, either, and probably new mostly kid-oriented sets wouldn't fill the space for me that I fill today with MOCs and whatnot. That's why I chose to change the hashtag to #keepLEGOCastleAlive, let's keep LEGO Castle alive, MOC to MOC. The idea of not letting it die but on the contrary, letting it evolve as LEGO evolves with new pieces, and as we evolve. . . those of us who create, as we improve. It seems to me much better than the attitude of complaining because LEGO has discontinued the line.

**HBM:** I think we will have some new Castle by the time this issue comes out, or so the rumor mill says.

**GC:** I hope so, although according to the leak, it's going to cost me a kidney to bring it here.

**HBM:** We'll see. Thank you very much, Gonzalo, for dedicating this time with your words and instructions!

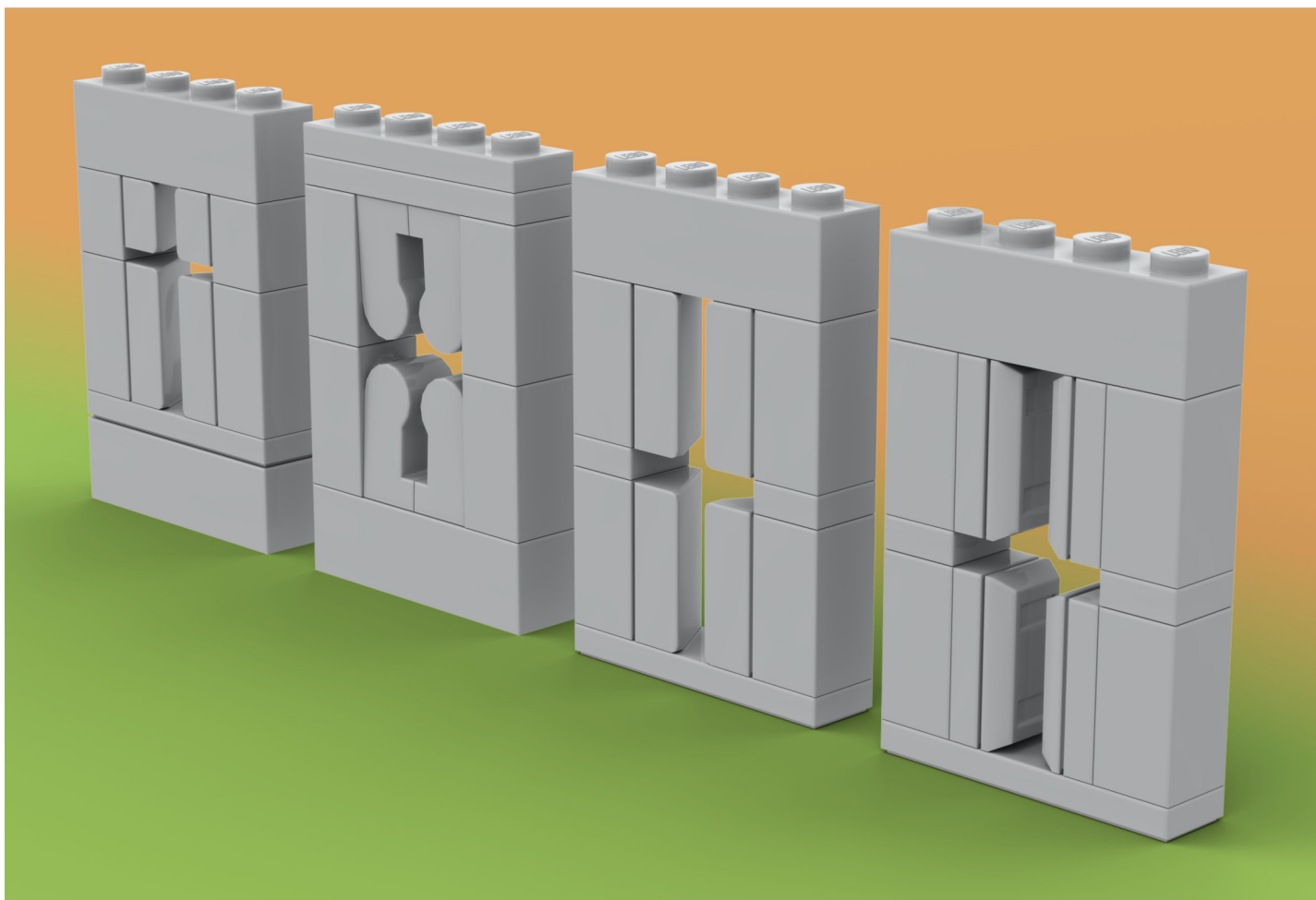

# Window Slits

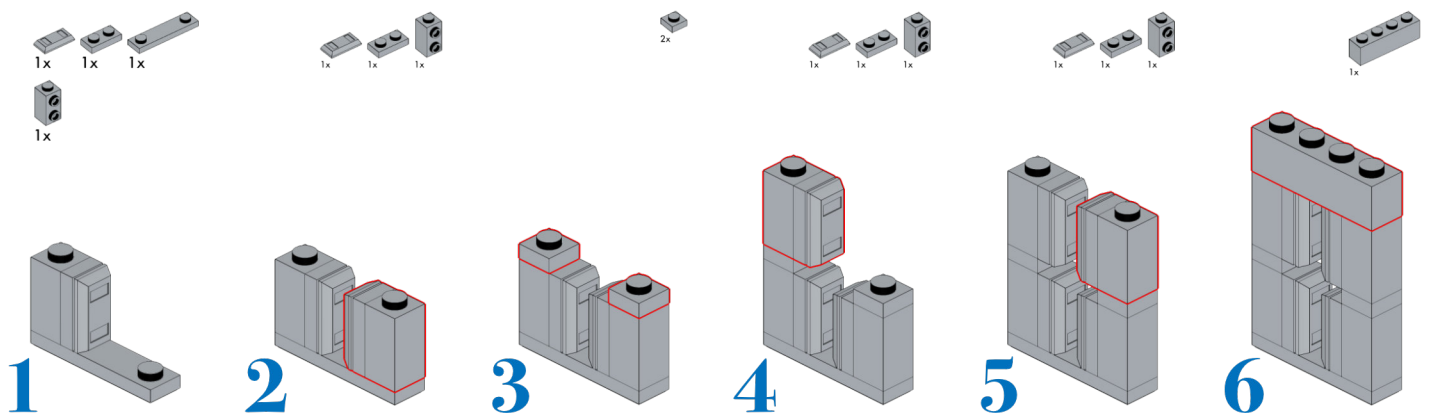
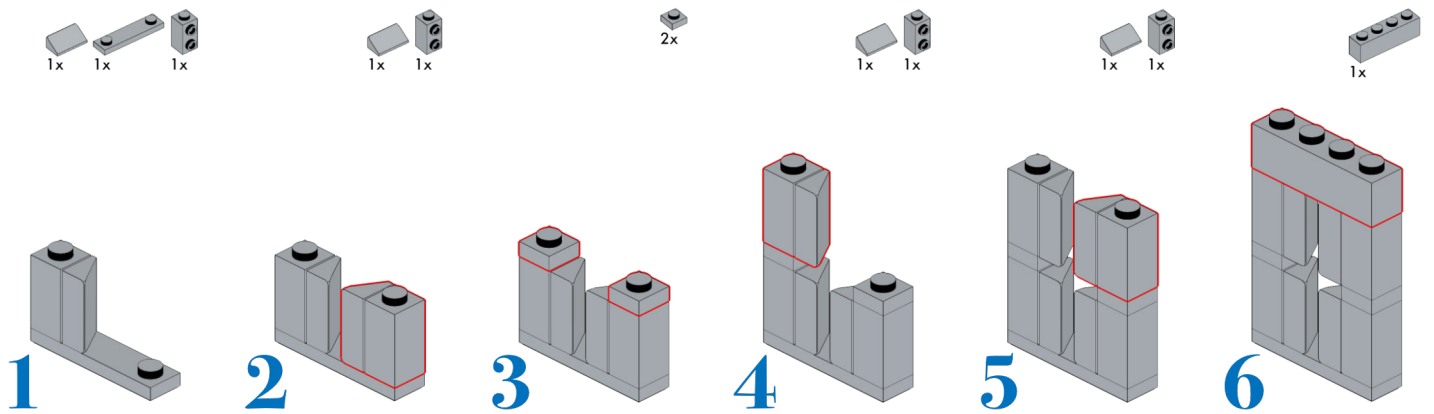
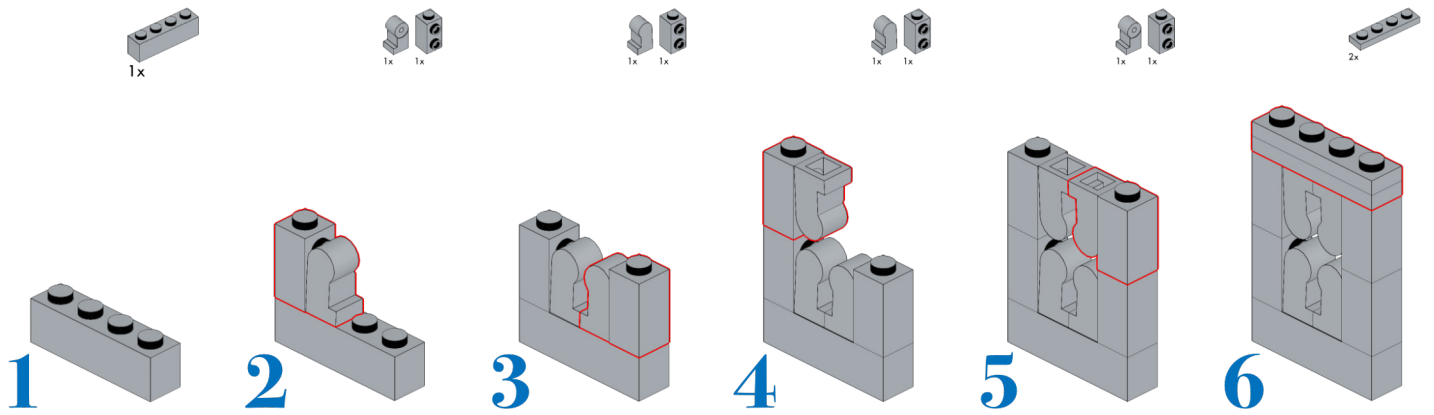
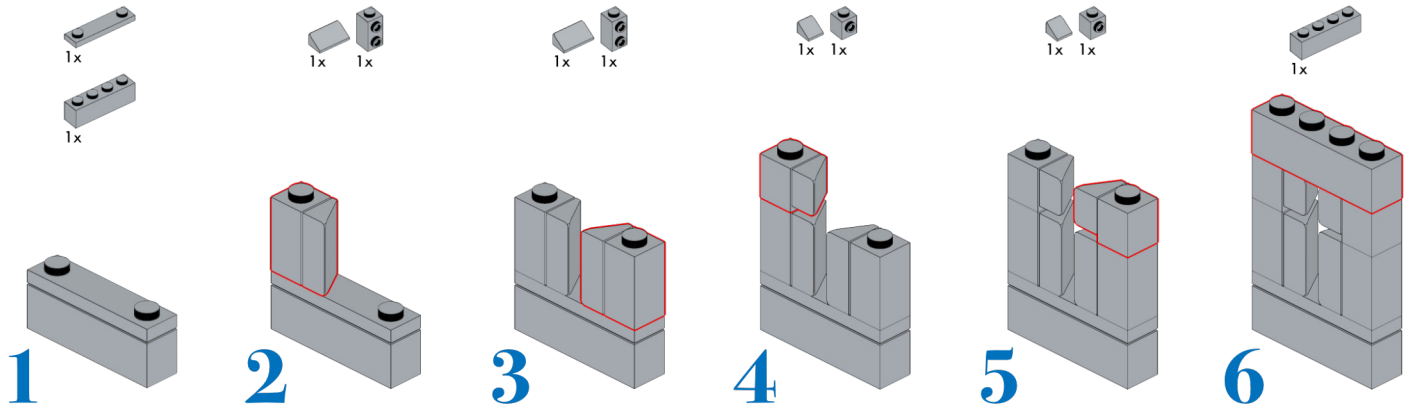



# Modular Gatehouse



1

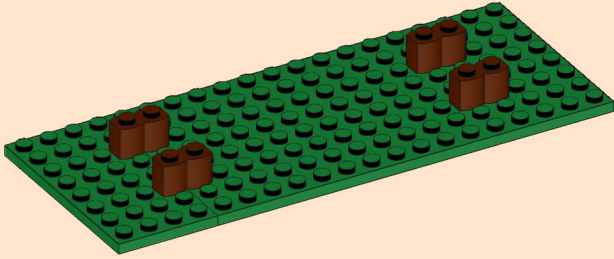
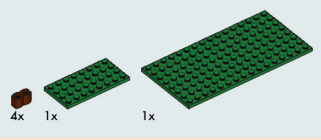

2

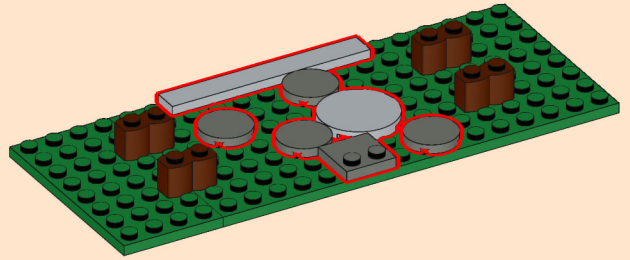
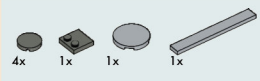

3

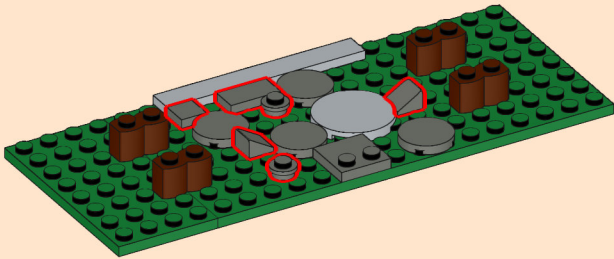

4

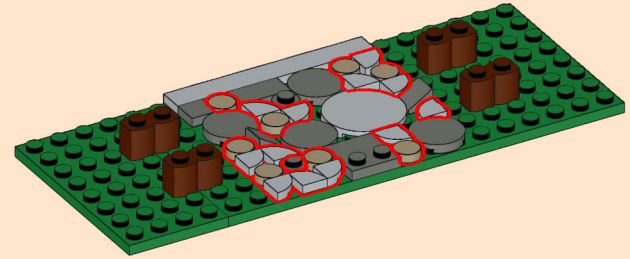

5

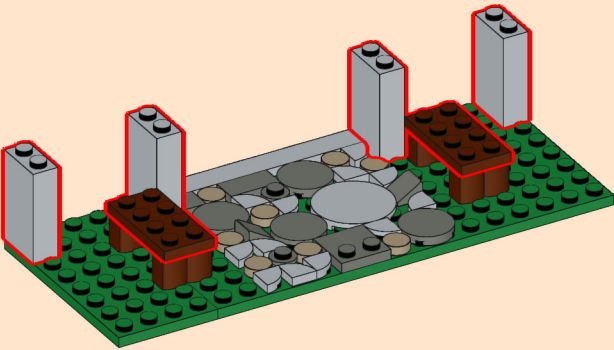
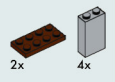

6

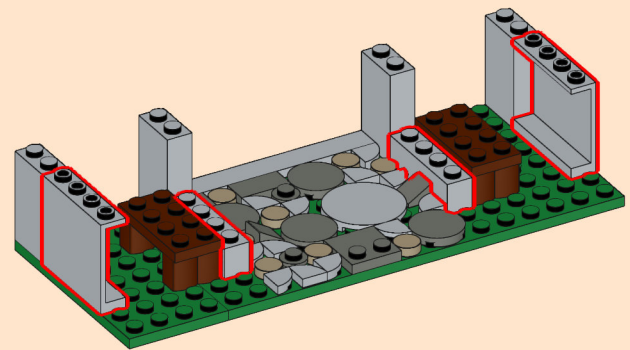
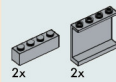

7

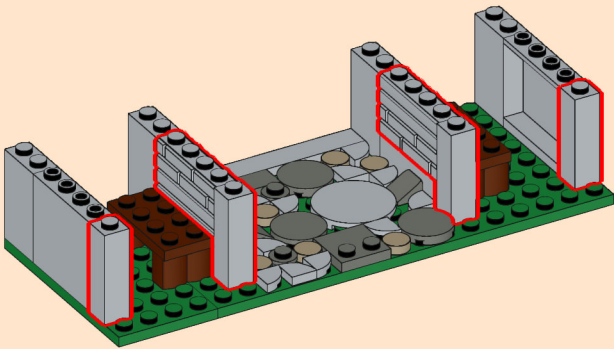

8

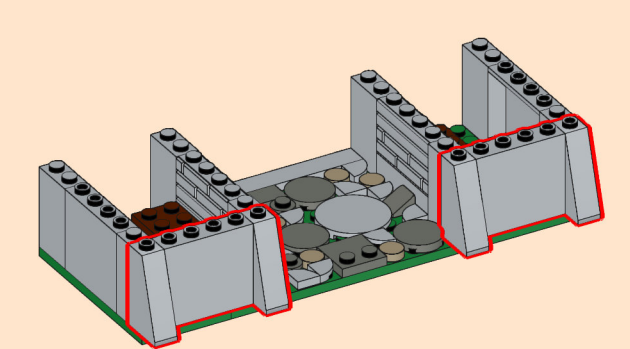
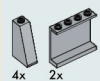



9

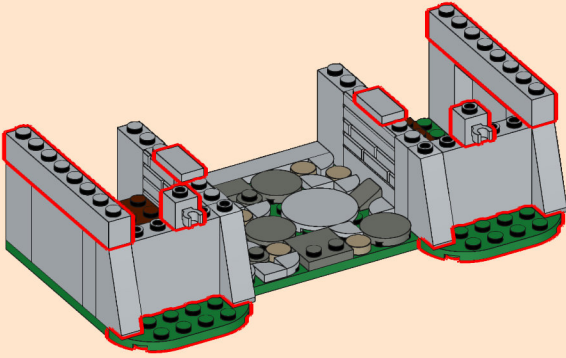
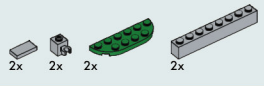

10

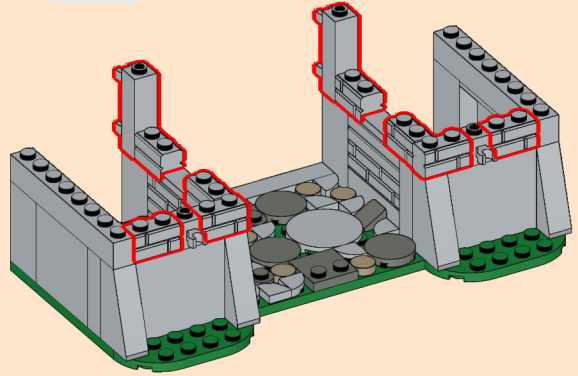

11

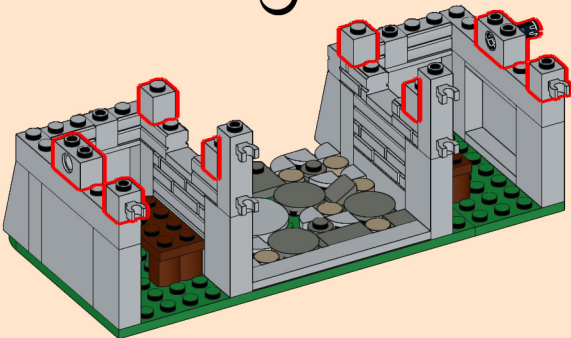
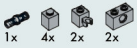

12

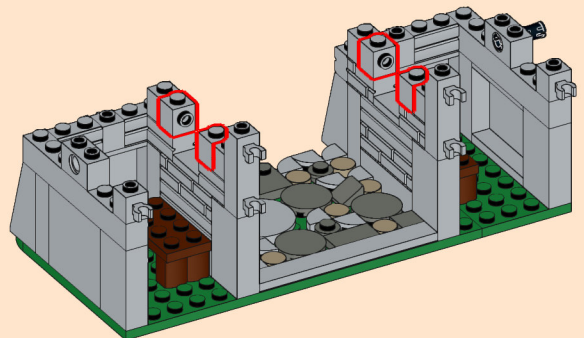

13

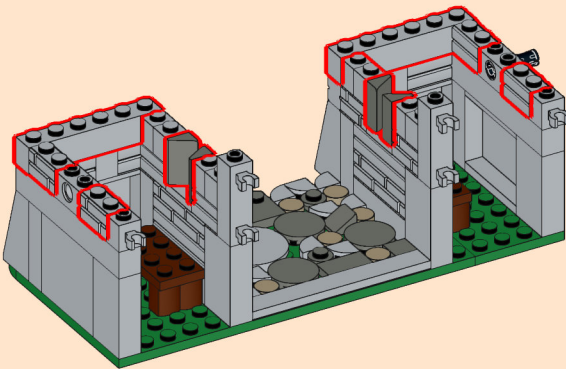
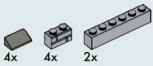

14

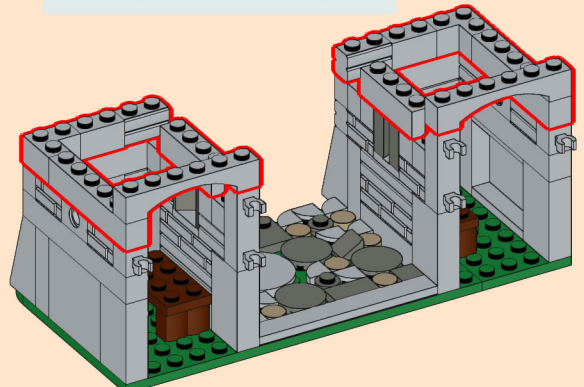
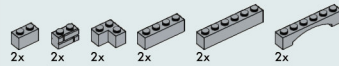

15

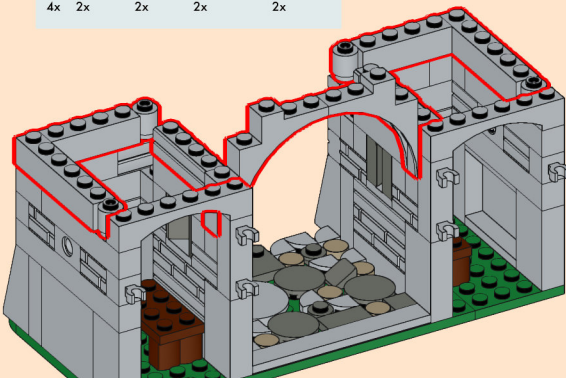
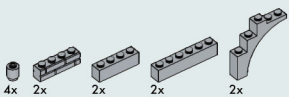

16

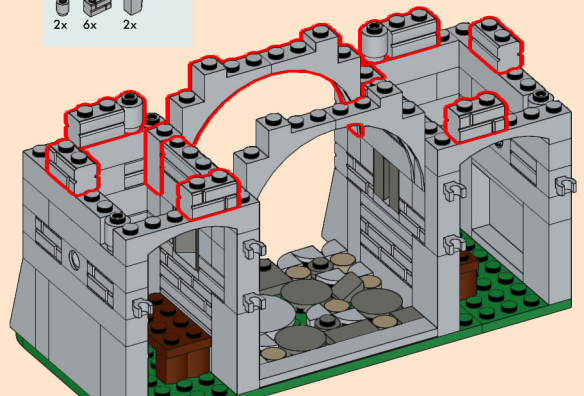
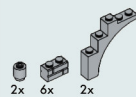

17

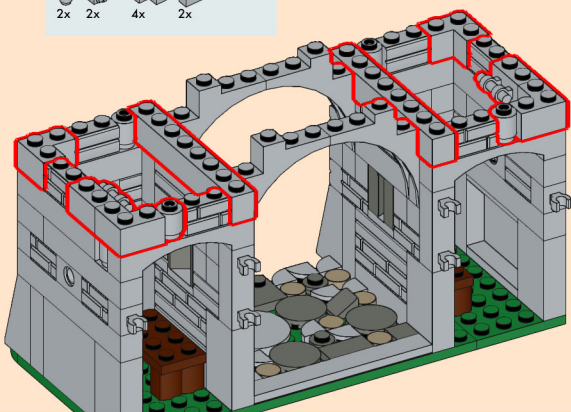
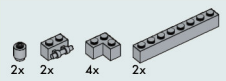

18

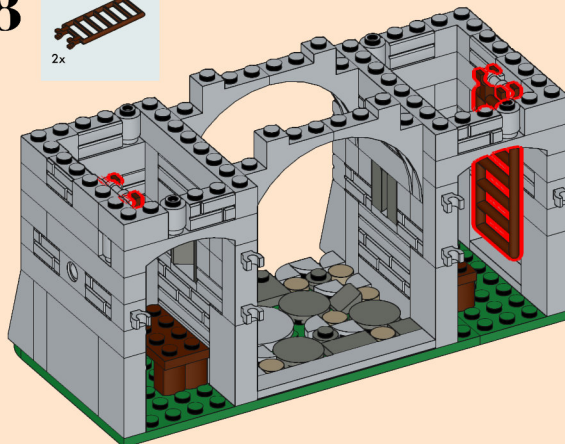

19

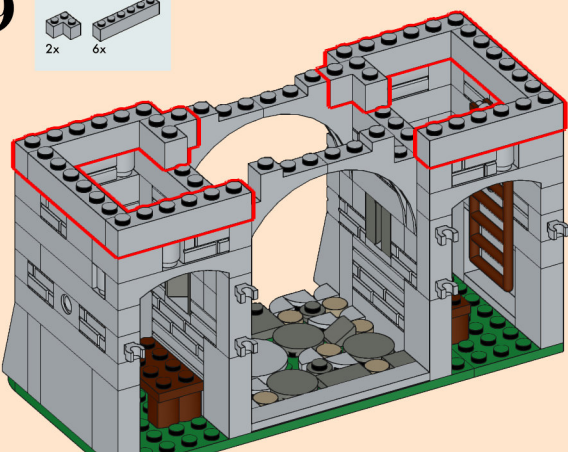
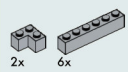

20

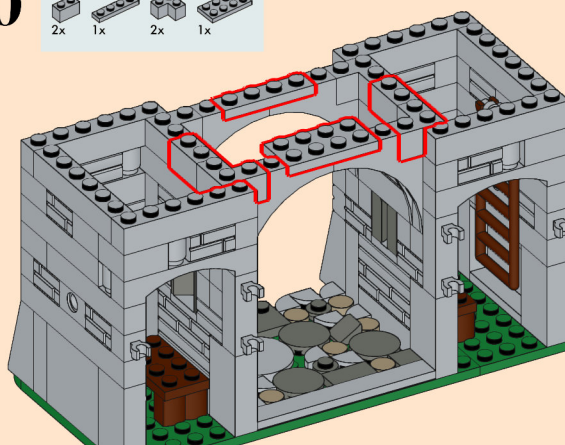
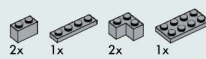

21

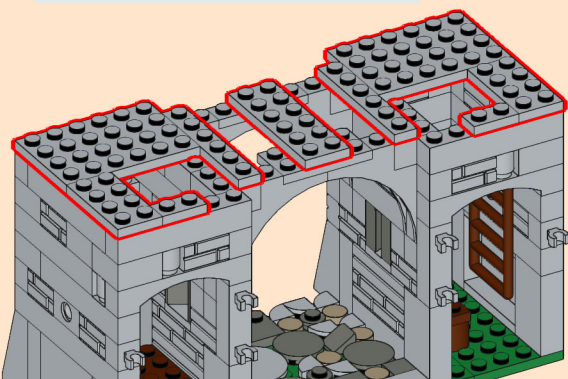
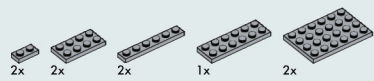

22

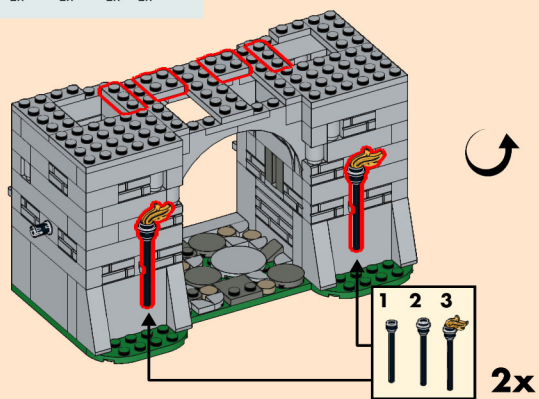
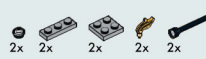

23

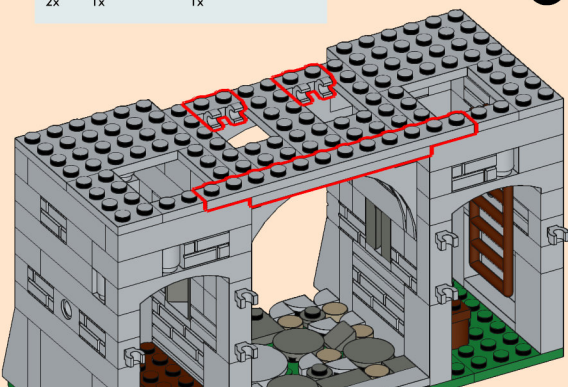
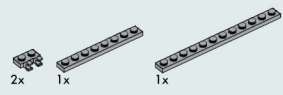

24

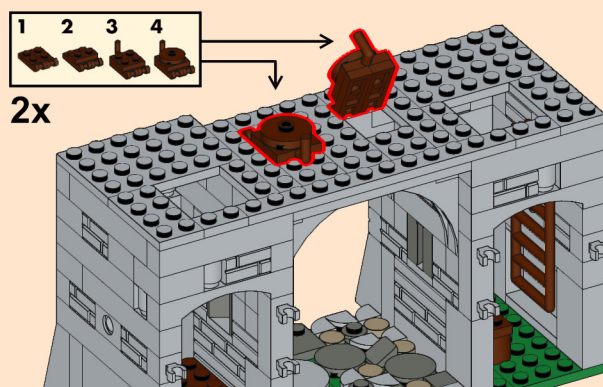



25

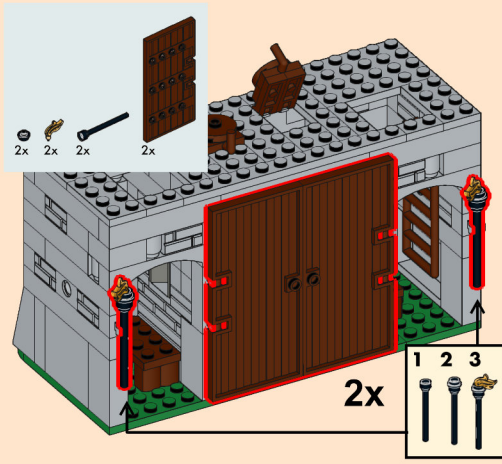

26

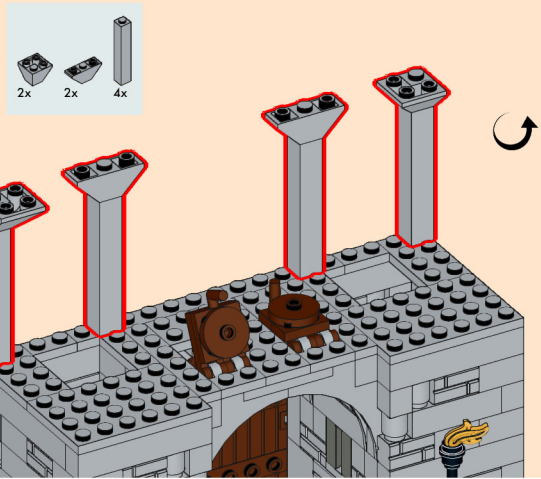

27

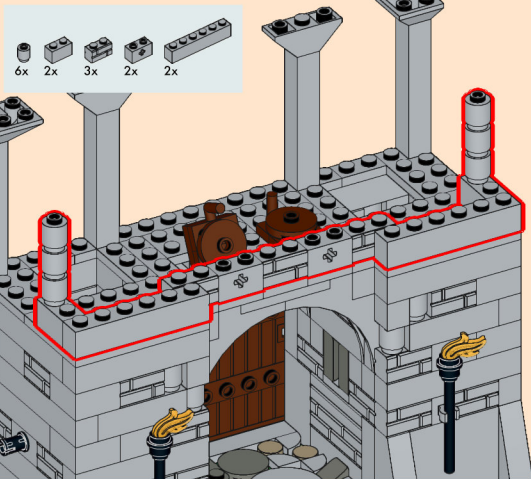

28

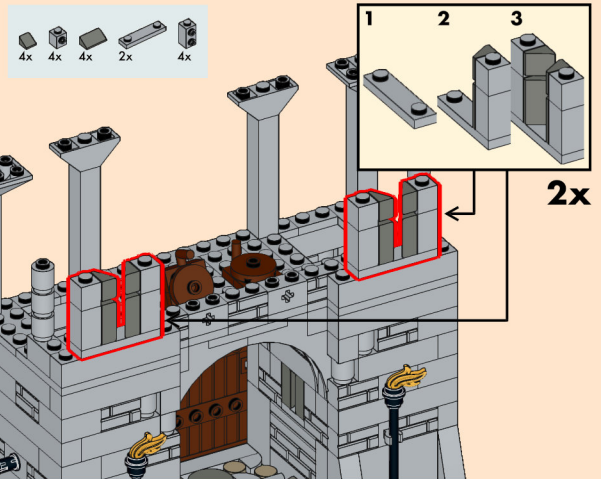

29

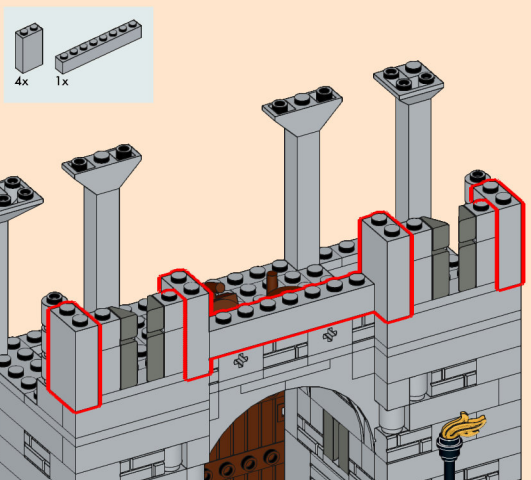

30

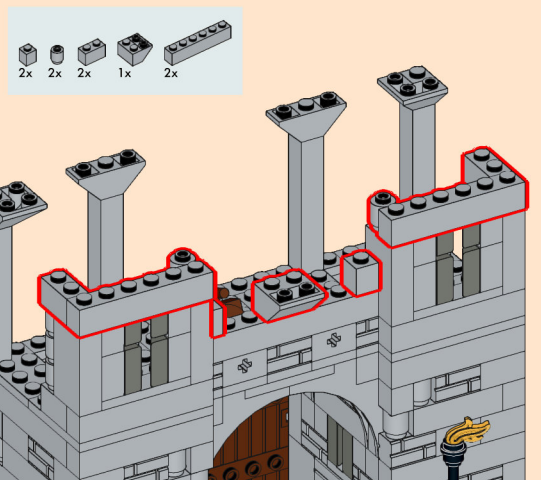

31

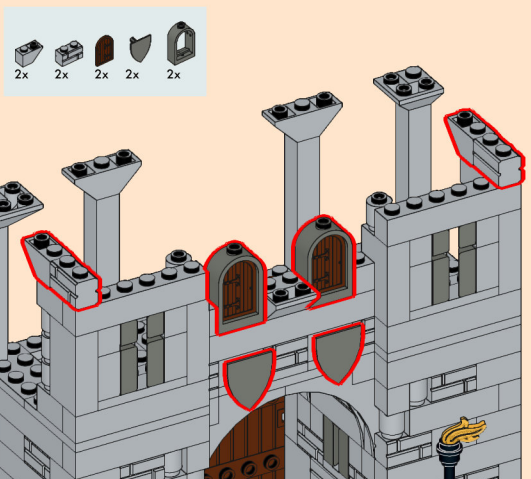

32

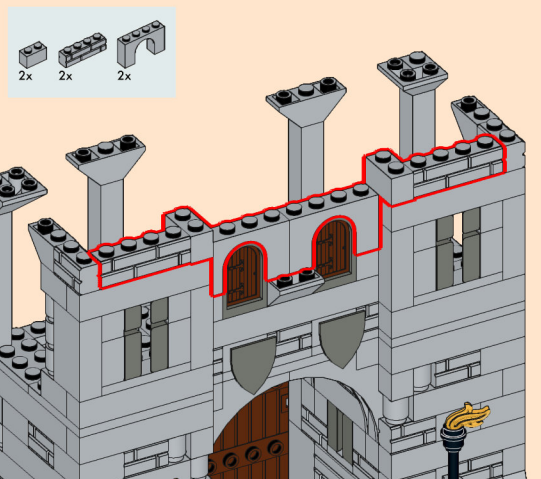

33

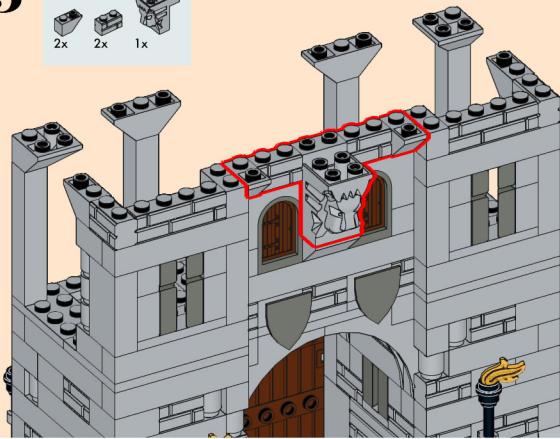
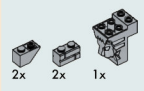

34

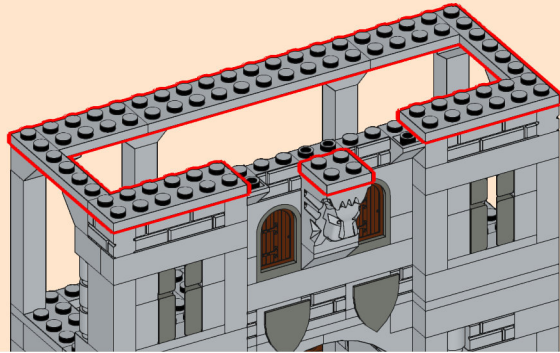
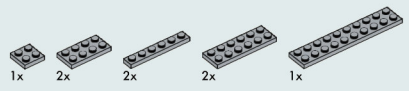

35



36



37

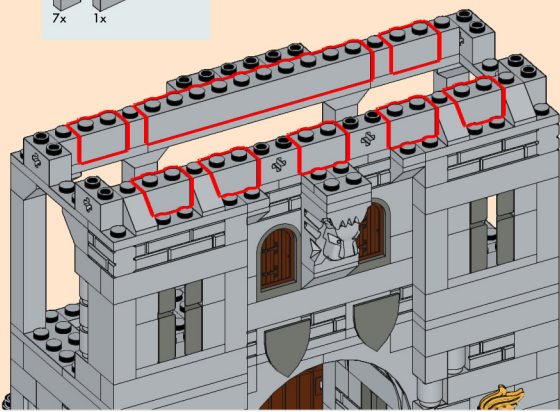
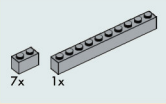

38

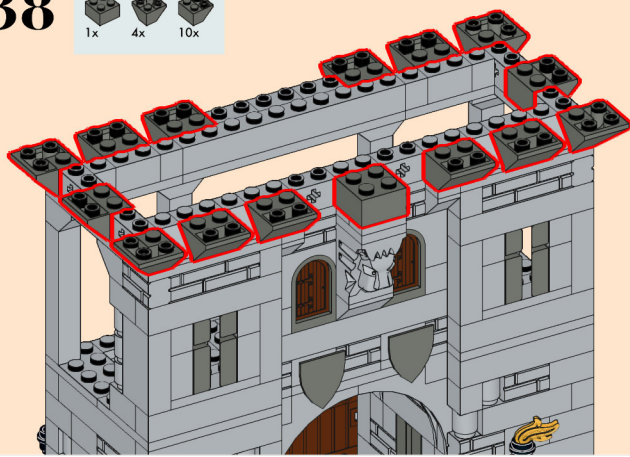
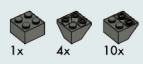

39

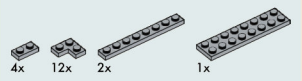

40

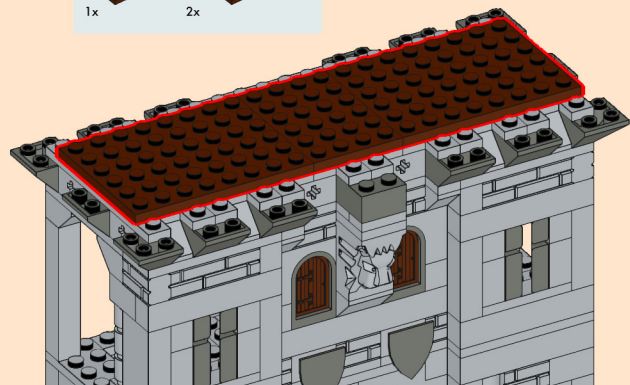
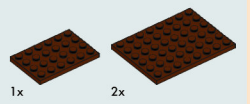



41

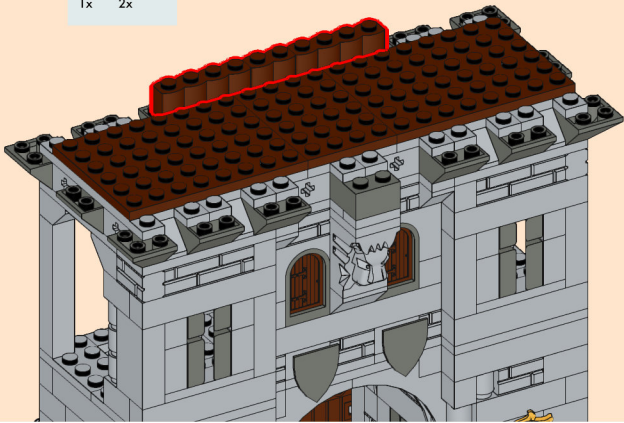

42

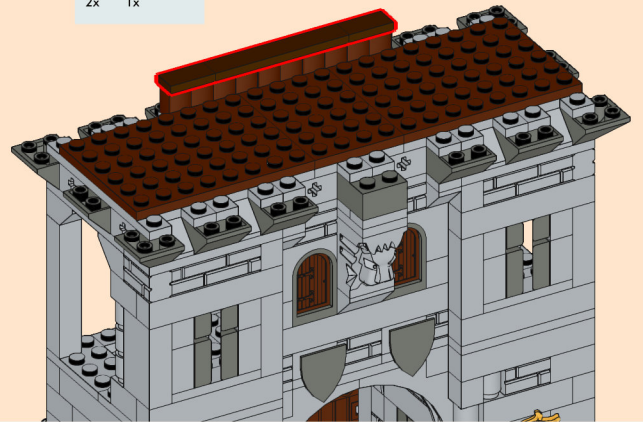
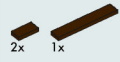

43

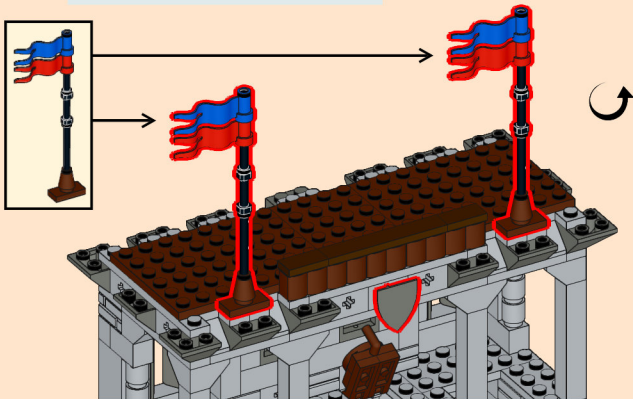

44

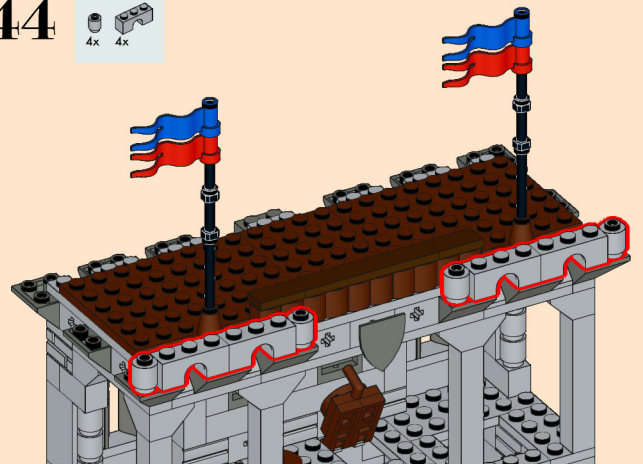

45

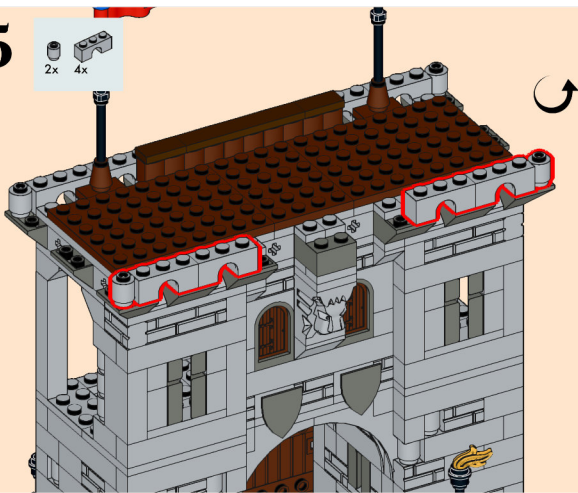

46

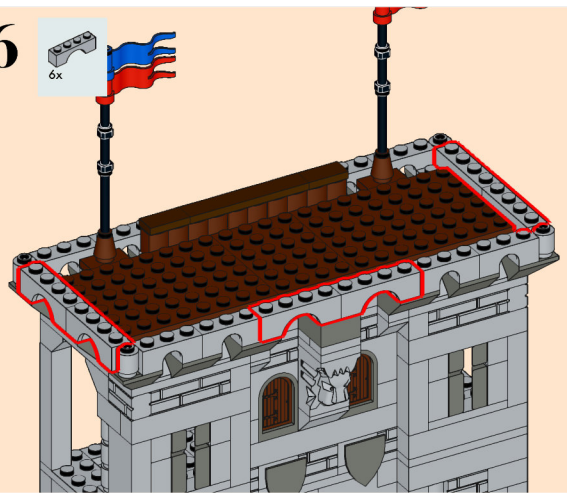

47

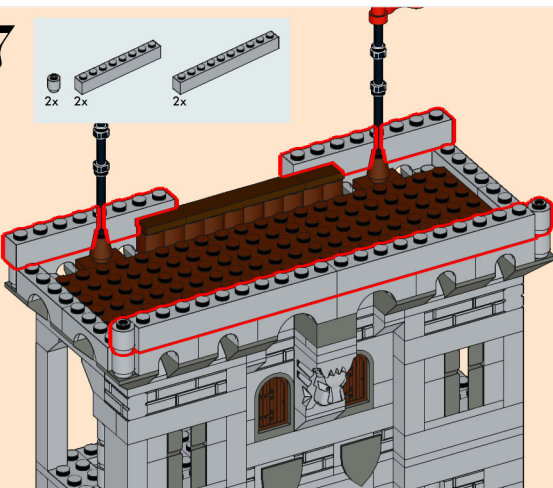
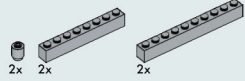

48

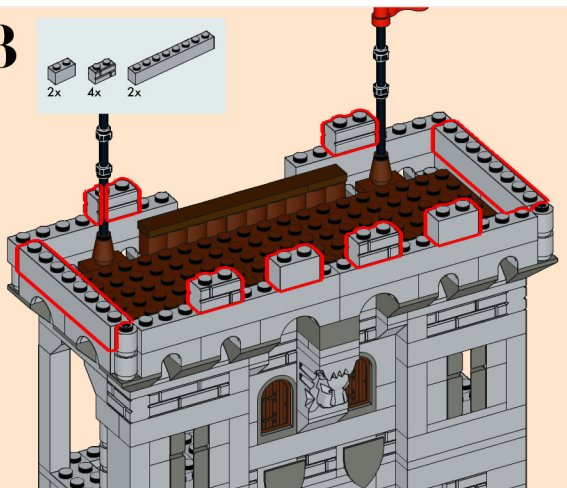
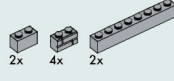

49

13x

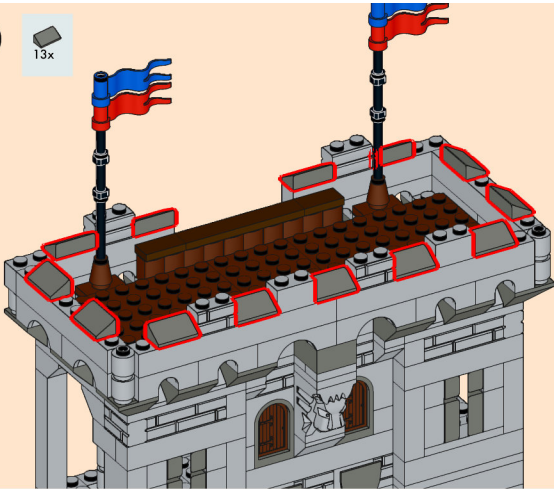

50

8x 2x 4x

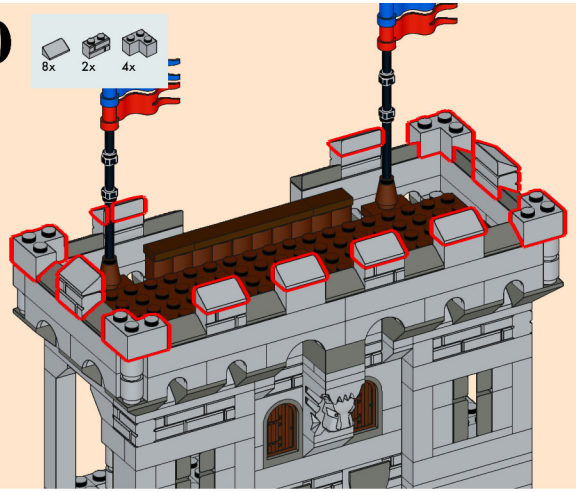

51

4x 4x

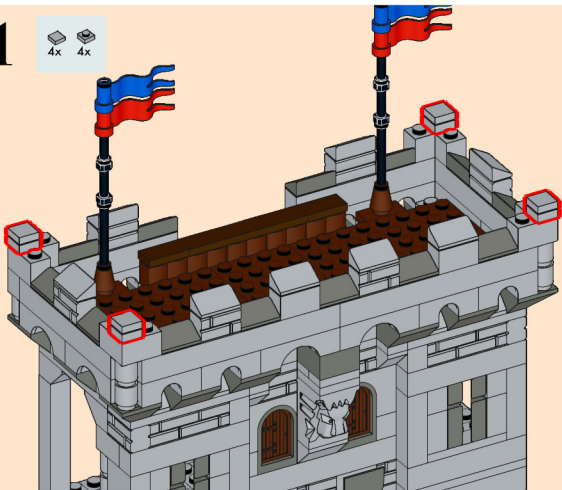

52

8x

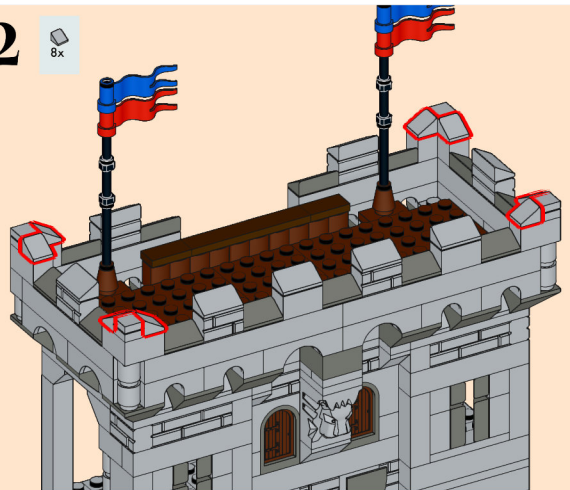





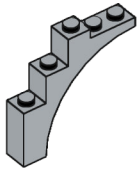

4x  
2339  
Light Bluish Gray



2x  
3032  
Light Bluish Gray

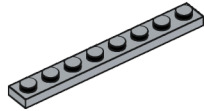

3x  
3460  
Light Bluish Gray

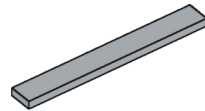

1x  
4162  
Light Bluish Gray

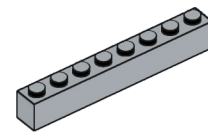

9x  
3008  
Light Bluish Gray

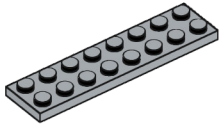

1x  
3034  
Light Bluish Gray

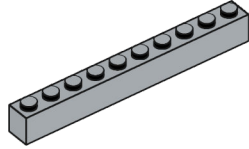

3x  
6111  
Light Bluish Gray

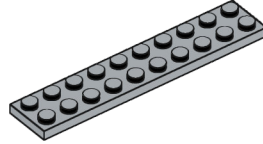

1x  
3832  
Light Bluish Gray

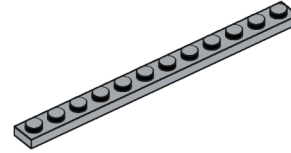

1x  
60479  
Light Bluish Gray



2x  
4495a  
Red



2x  
4589b  
Reddish Brown



2x  
15573  
Reddish Brown



2x  
3023  
Reddish Brown



5x  
30136  
Reddish Brown



2x  
18674  
Reddish Brown



2x  
4623b  
Reddish Brown



4x  
60478  
Reddish Brown



2x  
94161  
Reddish Brown

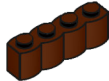

2x  
30137  
Reddish Brown



2x  
3020  
Reddish Brown



1x  
3032  
Reddish Brown

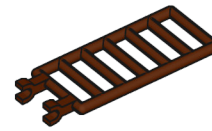

2x  
6020  
Reddish Brown

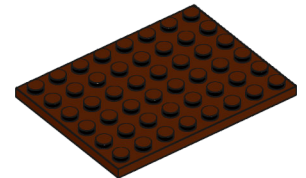

2x  
3036  
Reddish Brown

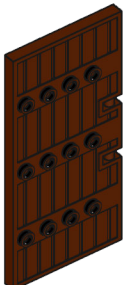

2x  
87601  
Reddish Brown



2x  
3069b  
Dark Brown



1x  
6636  
Dark Brown



8x  
98138  
Dark Tan



2x  
18980  
Green

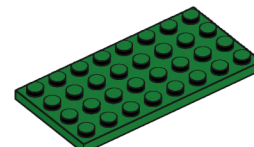

1x  
3035  
Green

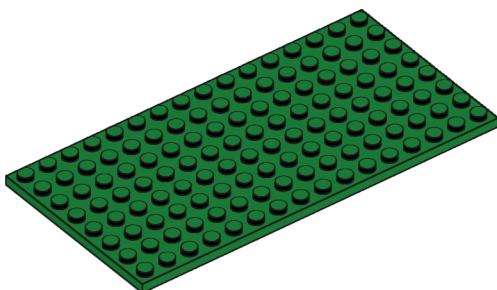

1x  
92438  
Green



2x  
4495a  
Blue



4x  
64647  
Luminous Soft Amber